

БТ-52 БТ-56

NO.	DESCRIPTION	NO.	DESCRIPTION	NO.	DESCRIPTION
1	GEAR CASE ASSY	31	HARNESSESS CLAMP	61	HAND GRIP
2	STOP RING	32	CLAMP	62	SPRING
3	STOP RING	33	SCREW M5X20	63	BOX RIGHT
4	BEARING 6000Z	34	NUT M5	64	SCREW ST2.9X18
5	PINION	35	CLUTCH COMP	65	SCREW M5X30
6	STEEL PLATE	36	CLUTCH DRUM COMP	66	CABLE COMP
7	CAPSCREW M5X20	37	STOP RING	67	TUBE
8	WASHER	38	BEARING 6202	68	STOP BUTTON COMP
9	SCREW M5X12	39	STOP RING	69	HAND GRIP
10	BOLT M6X12	40	UNKER	70	SPRING
11	WASHER	41	RUBBER COVER	71	BOX LEFT
12	GEAR CASE	42	SCREW M5X20	72	NYLON CUTTER HAND
13	BLADE COVER	43	SCREW M5X12	73	CASE
14	BEARING 6000Z	44	STOP RING	74	LEFT NUT
15	GEAR	46	CLAMP	75	WASHER
16	SHAFT	47	WIRE CLAMP BAND	76	SPRING
17	BEARING6002	48	HARNESSESS ASSY	77	NYLON CORD
18	STOP RING	49	BOLT M5X25	78	CORD HOLDER
19	HOLDER	50	CAPLOWER	79	PLATEN
20	HOLDER	51	BRACKET	80	COVER
21	HOLDER	52	HANDLE	81	BRACKET
22	LEFT NUT	53	GRIP LEFT	82	SCREW M5X30
C24	BLADE	54	CAP OPPER	83	SAFETY GUARD
25	PIPE COMP	55	HANDLE	84	WASHER
26	RUBBER COVER	56	LEVER ASSY	85	SCREW M5X16
27	OIL BEARING	57	SCREW ST2.9X13	87	GUARD
28	DRIVE SHAFT	58	BUTTON	88	BLADE
29	PIPE	59	SPRING	89	GUARD ASSY
30	HOLDER ASSY	60	CLOCK PIN		

RU-EN20180919
VER:1.3

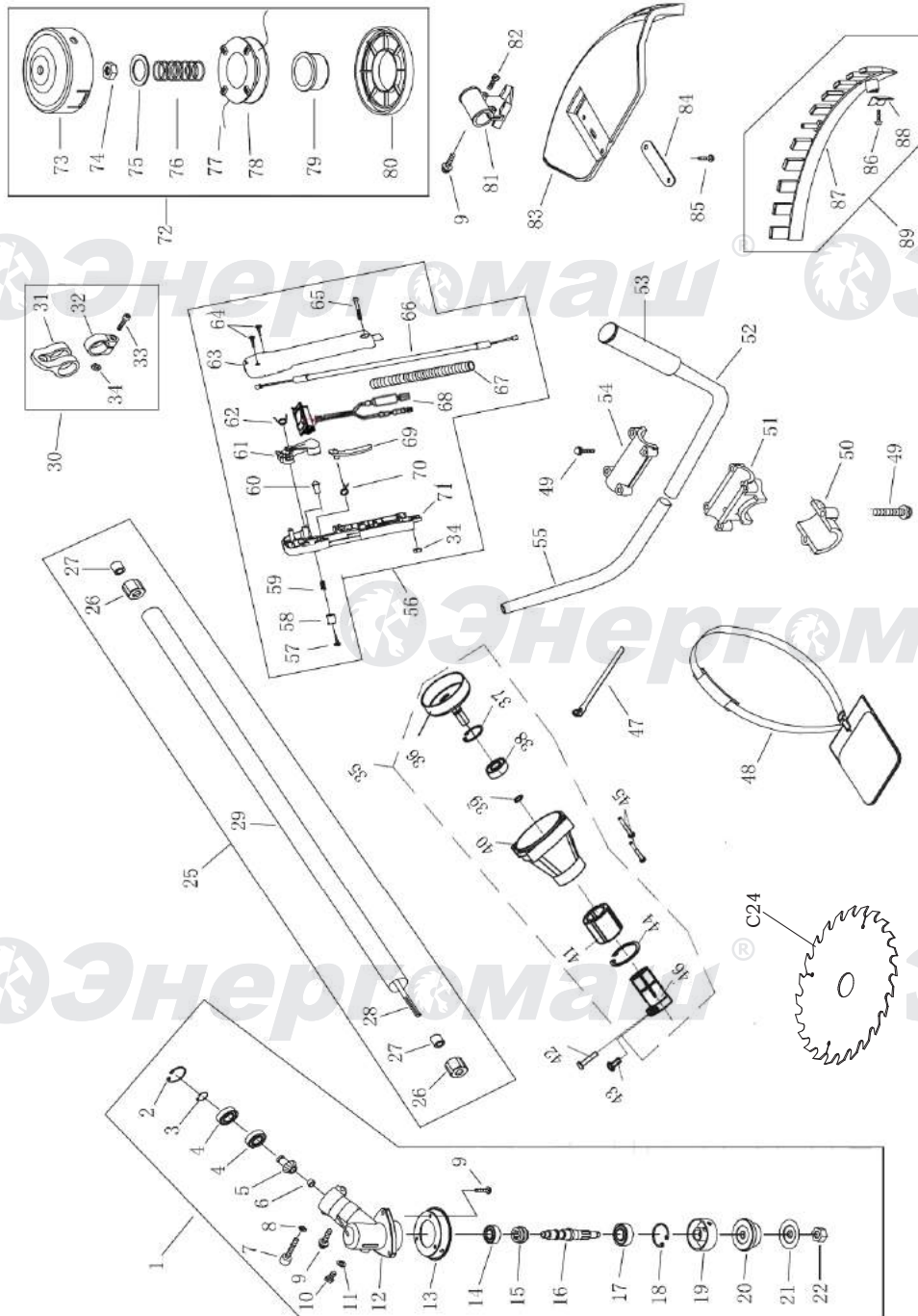

ЭЛЕКТРОДВИГАТЕЛЬ ДЛЯ БТ-52 БТ-56

NO.	DESCRIPTION	NO.	DESCRIPTION	NO.	DESCRIPTION
9	SCREW M5X20	44	CYLINDER	69-10	EASY START COIL SPRING
10	GASKET	45	SCREW	76	SCREW M5X16
11	NUT	46	GUIDE COVER ASSY	77	CLEANER COVER
16	OIL SEAL	47	SPARK PLUG	78	OUTLET FUEL PIPE
17	CRANK CASE	48	SPRING	79	PLUG
18	BEARING 6202	49	PLUG COVER	80	INLET FUEL PIPE
19	CRANKSHAFT	50	PLUG CAP	81	FUEL TANK
20	KEY	51	PLUG	82	LID ASSY
21	PIN	52	UPPER COVER	82-1	FUEL TANK LID
22	RUBBER WASHER	53	SCREW	82-2	GASKET
23	CRANK CASE	54	GASKET	82-3	INLET
25	SCREW M5X30	55	MUFFLER	82-4	INSIDE COVER
26	MAGNETO ROTOR COMP	56	SCREW	82-5	LID
27	NUT	57	BOLT	82-6	CHAIN
28	IGNITION COLL COMP	58	NUT	89	STAND
29	CORD COMP	59	MUFFLER COVER	90	RUBBER COVER
30	BOLT M5X20	60	GASKET	91	SCREW M5X20
31	WASHER	61	ADMITTING PIPE	93	STARTER PULLEY ASSY
32	SPRING	62	GASKET	93-1	STARTER REEL
33	EXPANDER	63	CARBURETOR	93-2	STOP RING
34	WASHER	69	STARTER	93-3	STARTER PAWL SPRING
35	SCREW PIN	69-1	SCREW	93-4	STARTER PAWL
36	FAN COVER	69-2	WASHER	94	AIRFILTER COVER
37	BEARING 10X14X16	69-3	START POPE REEL	95	AIR CLEANER
38	RING	69-4	POPE	96	AIRFILTER COVER SEAT
39	PISTON	69-5	RECOIL SPRING	97	SCREW
40	PISTON PIN	69-6	START COVER ASSY	98	CHOKE SEAT ASSY
41	GASKET	69-7	START HANDLE	99	SCREW
42	PISTON RING	69-8	RING	100	CIRCULAR COVER
43	GASKET	69-9	START RATCHET		

RU-EN20180919
VER:1.3

